

Speaker

Model: OSS12-42-13A0.25W100-P



ELECTRICAL SPECIFICATIONS

	Condition	Parameter	Unit
Sound Pressure Level	at 0.25W, 0.5M [at 1.2KHz]	70 ± 3	dB
Impedance	at 1V, 1000Hz	100 ± 15%	Ω
Rated Input Power		0.25	W
Max Input Power		0.5	W
Resonant Frequency (Fo)	at 1V	1200 ± 20%	Hz
Frequency Range		1200 ~ 5000	Hz
Buzzer & Rattles	not be audible at sine wave between 450 ~ 5KHz	5	V
Operating Temperature		-40 ~ 120	°C
Magnet		Nd-Fe-B	
Frame Material		PPE+PS	
Cone Material		Mylar (PEI)	
Weight		16.5	g

MECHANICAL DRAWING

Dimensions in mm

Tolerance ±0.5mm Except Specified

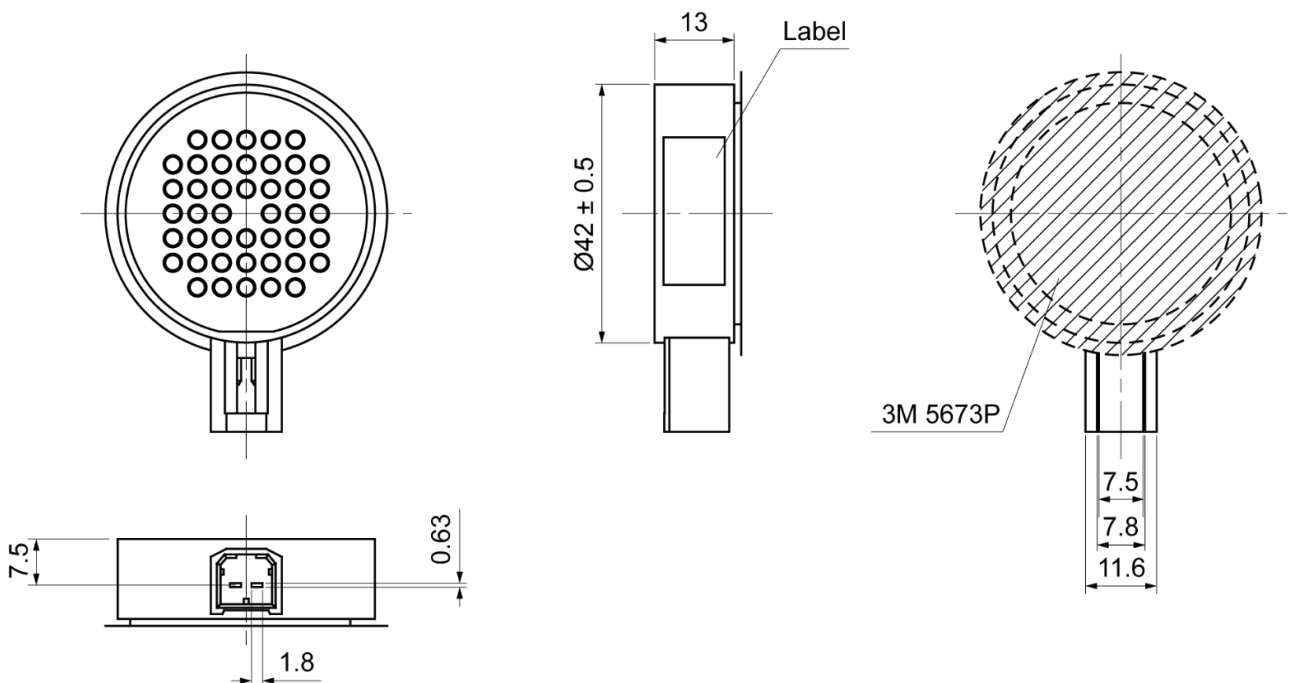

Speaker

Model: OSS12-42-13A0.25W100-P

FREQUENCY RESPONSE CURVE

square wave 0.25w 7.0Vp-p 0.5m

X: 200.00Hz Y: 38.58dB ZA: Live Curve SSR Fund.

A: Frequency Response, Magn dB re 20.00µPa/V

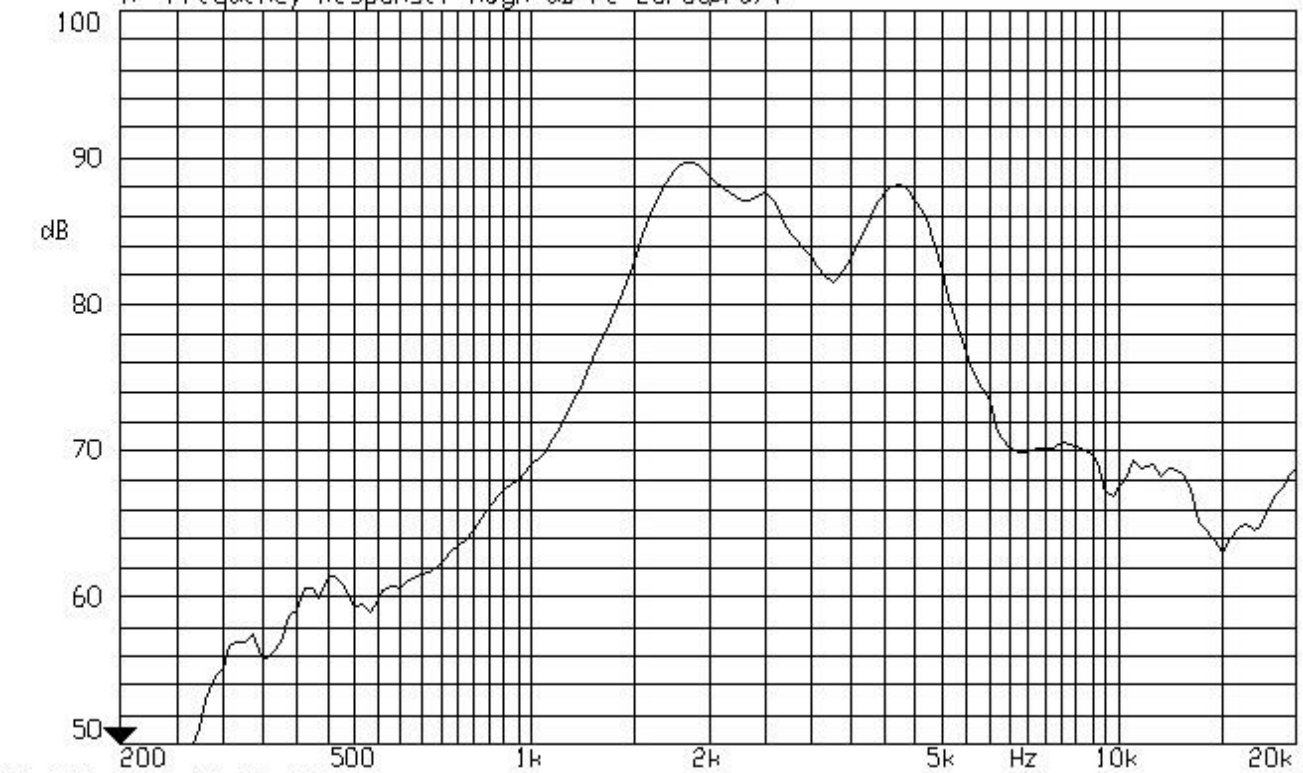

21-DEC-2010 15:19:48

Mode: SSR

